

Question block created by wizard

This exam contains 108 questions

1. The axes (normal , longitudinal and lateral) of an aircraft will pass?

- (a) The pressure point.
- (b) Zonal station 0.
- (c) The Centre of Gravity.

If choice c is selected set score to 1.

2. When an aircraft is trimmed....

- (a) all fuel tanks are equally filled with kerosene.
- (b) the pilot can fly loose hands.
- (c) all flight controls are calibrated on the 0 degrees.

If choice b is selected set score to 1.

3. If the Mach number is 0,74 then the category is?

- (a) Transonic.
- (b) Subsonic.
- (c) Supersonic.

If choice b is selected set score to 1.

4. When the angle of a wing sweepback increases?

- (a) The critical Mach number decreases.
- (b) The critical Mach number remains the same.
- (c) The critical Mach number increases.

If choice c is selected set score to 1.

5. What is the meaning of a "fail-safe structural design"?

- (a) It indicates that structural loads are shared over multiple parts.
- (b) It means that in case of partial structural failure the pilot will be informed by a caution warning.
- (c) It is just a fancy expression used as commercial argument.

If choice a is selected set score to 1.

6. What is the function of the Static dischargers?

- (a) In case of a static charge they lead the electrical energy off the aircraft.
- o (b) They will protect the communication systems against a lightning strike.
- o (c) They function as a communication antenna.

If choice a is selected set score to 1.

7. Where do we usually apply honeycomb structures?

- o (a) Only on the aerodynamic fairings and internal components like floor panels.
- (b) Floor panels, fairings, wing panels, flight control surfaces.
- o (c) Only on the interior panels, honeycomb structures do not withstand humidity.

If choice b is selected set score to 1.

8. Why do they use more and more bonded metal to metal joints on the latest aircraft?

A bonded metal to metal joint is....

- (a) normally stronger.
- o (b) a fast way to construct. Time is money.
- o (c) much cheaper because you don't need the rivets and labor.

If choice a is selected set score to 1.

9. Why are there so many structural reinforcements around the landing gear attachments?

- o (a) You will find only a lot of structural reinforcements on aircraft with retractable gears. This is to support the big torque forces during gear retraction.
- o (b) The main reason for these reinforcements is to support the vibrations while running over taxi ways. It is financially not possible to build taxi ways so smooth and even as the runways.
- (c) The landing gear loads are the largest on the aircraft and it requires a lot of reinforcement to transfer these loads into the aircraft.

If choice c is selected set score to 1.

10. What is a plug type door?

- (a) It is a door that is closed from inside to outwards, that way it pushes against its door stops and is impossible to force open when the aircraft is pressurized.
- o (b) It is a door that is closed from inside to outwards, that way it pushes against its door stop. It needs a special locking because the door can be forced open when pressurized.
- o (c) It is a passenger door that slides upwards into the interior ceiling when opened. (typical DC 10)

If choice a is selected set score to 1.

11. Concerning the spoilers, which statement is correct?

- (a) Flight spoilers are used to increase lift.
- (b) Aircraft spoilers have the same function as on a car, they improve the aerodynamics.
- (c) Flight spoilers create drag and so can have a roll function or a speed brake function.

If choice c is selected set score to 1.

12. On modern aircraft, where can the fuel be stored?

- (a) In the cargo area.
- (b) In the engine pylons.
- (c) In the wings, in the centre-tank and stabilizer.

If choice c is selected set score to 1.

13. What can be an advantage of a T-tail configuration?

- (a) The stabilizer needs a smaller surface, reducing drag.
- (b) It creates the possibility to have rear mounted engines.
- (c) The horizontal surfaces are out of a potential turbulent air stream created by the main wings or the engines attached to the wing.

If choice c is selected set score to 1.

14. Where are static dischargers normally installed on flight controls?

- (a) Nose edge.
- (b) Trailing edge.
- (c) Leading edge.

If choice b is selected set score to 1.

15. To eliminate flutter by high speed flight, control surfaces should be....

- (a) locked by the pilot.
- (b) balanced.
- (c) extended.

If choice b is selected set score to 1.

16. Why is the leading edge of the nose cowl of an engine made out of metal?

- o (a) Resistance for bird strike impacts. Metal is stronger and the risk is potential.
- (b) The nose cowl leading edge needs to be anti-iced with hot air.
- o (c) Cost, such a round bended shape in composite is too expensive.

If choice b is selected set score to 1.

17. What should be the general function of a fire seal?

- o (a) Ensures propagation of the fire to other compartments where it can be extinguished.
- o (b) Drain fluid leaks. Contain hot air gasses within the section.
- (c) Prevent entry combustible fluids in dangerous areas.

If choice c is selected set score to 1.

18. Can the cabin be air conditioned when the packs are inoperative?

- o (a) No, conditioning air can only be supplied by the packs.
- o (b) Yes, in flight by the emergency ram air conditioning pack. On ground by an external air-conditioning ground source.
- (c) Yes, but only on the ground by an external air-conditioning ground source who supplies conditioned air directly into the cabin.

If choice c is selected set score to 1.

19. Why do we need a cabin environment system on board of a modern airliner?

At economic cruising altitudes, the air is too....

- o (a) dry and due to the high aircraft speed we need to control the air flow speed within the cabin.
- o (b) dry and too cold to survive.
- (c) cold and contains not enough oxygen to survive.

If choice c is selected set score to 1.

20. What type of air-conditioning system is shown in this picture?

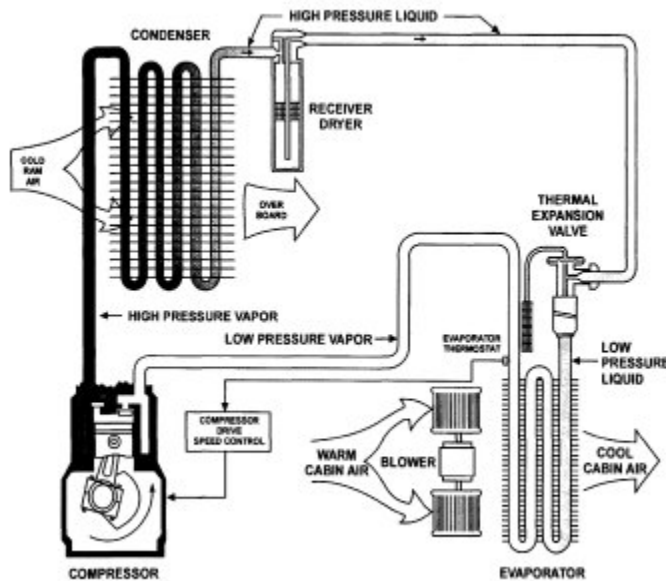

- (a) The condenser re-heater air conditioning system.
- (b) The double cooler air cycle machine.
- (c) The vapour cycle machine.

If choice c is selected set score to 1.

21. In an air-conditioning pack, why do we have an anti-ice valve and how does it work?

- (a) To protect the system when icing occurs in the water separator. Hot air will bypass the ACM and be used to heat up the water separator.
- (b) To protect the system when icing occurs in the water separator. Hot air from the anti-ice valve will close as protection the pack flow valve.
- (c) To protect the system when icing occurs in the turbine exit. Hot air will bypass the ACM and so the turbine will slow down.

If choice a is selected set score to 1.

22. Does the temperature in the cabin remain stable once regulated?

- (a) Yes, it does not change much once stabilized.
- (b) No, it will change a lot, depending on the engine thrust settings.
- (c) No, it will change a lot during boarding, during climb and descent.

If choice c is selected set score to 1.

23. Why does an aircraft needs to be pressurized?

- (a) If we do not pressurize we cannot heat the cabin.
- (b) Passenger comfort, but it is not necessary .
- (c) To create, by pressurizing, a safe atmosphere.

If choice c is selected set score to 1.

24. What are the basic components in an pressurization system?

A pressure controller and a control panel, an outflow valve,....

- (a) a pressure relief valve and negative pressure relief valve.
- (b) an equipment cooling exhaust valve, a negative relief valve.
- (c) a negative relief valve.

If choice a is selected set score to 1.

25. Why is it so important to check that you never apply a negative pressure in the air-conditioning and ventilation ducts?

- (a) With a negative pressure you will risk to drive the ACM (Air Cycle Machine) in the wrong direction. This will damage the bearings of the ACM.
- (b) A negative pressure will produce a reverse flow in the system. This can damage the check valves.
- (c) Some of the ducts are thin wall ducts. They can handle positive pressure but will collapse on negative pressure.

If choice c is selected set score to 1.

26. What are some of the most important precautions to take when working at the air systems?

- (a) Make sure the system is depressurized and deactivated.
- (b) Make sure that the engine and apu igniters systems are deactivated.
- (c) Make sure you have the correct tools. Some titanium ducts can be damaged by chrome molybdenum wrenches. Expensive damage will follow.

If choice a is selected set score to 1.

27. Static pressure:

- (a) is the dynamic pressure of the air due to the forward motion of the aircraft.
- (b) is the outside air pressure at the instant of measuring.
- (c) is the total pressure inside the aircraft.

If choice b is selected set score to 1.

28. An attitude Indicator:

- o (a) gives a representation of the aircraft to its horizontal axis.
- o (b) displays a pictorial plan of the aircraft's situation in the horizontal plane.
- (c) gives a representation of the aircraft's pitch and roll attitudes relative to the earth.

If choice c is selected set score to 1.

29. A wing will stall...

- (a) at any airspeed, altitude and power setting, and it always stalls at the same AOA.
- o (b) due to excessive Fuel weight, 'G' loading or angle bank.
- o (c) when the airflow separates due to a minimum of AOA.

If choice a is selected set score to 1.

30. The Electronic Attitude Director Indicator (EADI):

- (a) is indicating pitch and roll attitude.
- o (b) presents a selectable, dynamic colour display of flight progress and plan view orientation.
- o (c) also allows other features such as MAP and Weather Radar displays to be selected.

If choice a is selected set score to 1.

31. What is pitot pressure?

- o (a) It is the total pressure inside the aircraft.
- (b) It is the dynamic pressure of the air due to the forward motion of the aircraft.
- o (c) It is the outside air pressure at the instant of measuring.

If choice b is selected set score to 1.

32. The Cabin Interphone:

- o (a) takes care of the communication among maintenance personnel during maintenance activities.
- o (b) enables recorded announcements and boarding music to be broadcast through the PA system.
- (c) allows the cabin crew to communicate with each other and with the flight deck crew.

If choice c is selected set score to 1.

33. The Passenger Entertainment System PES:

- o (a) provides primary the passenger with information on ambient aircraft flight data, times and aircraft position in the flight plan.
- (b) provides Video, Music, Interactive Video Games and In-seat Telephone System.
- o (c) provides attendant Call, Individual Reading Lights Control and No Smoking Light on/off.

If choice b is selected set score to 1.

34. The DME Distance Measurement gives information about:

- o (a) the ground distance from the aircraft to the selected ground station.
- o (b) the attitude of the aircraft.
- (c) the slant range to the selected ground station.

If choice c is selected set score to 1.

35. An aircraft battery charger:

- o (a) stops charging if there is a AC supply under-voltage (134V)
- o (b) charges all batteries in the aircraft.
- (c) is charging one particular battery.

If choice c is selected set score to 1.

36. A Ni-cd aircraft battery:

- o (a) has a nominal voltage of 24 V_{AC}.
- o (b) has a nominal voltage of 28 V_{DC}.
- (c) has 20 cells, 1,2V each.

If choice c is selected set score to 1.

37. A transformer rectifier unit converts....

- (a) 115 V_{AC} into 28 V_{DC}.
- o (b) 28 V_{AC} into 115 V_{DC}.
- o (c) 115 V_{AC} into 28 V_{AC}.

If choice a is selected set score to 1.

38. The three stages of an AC generator are PMG,

- o (a) exciter and GCU.

- (b) exciter and main alternator.
- o (c) GCU and main alternator.

If choice b is selected set score to 1.

39. Emergency electrical power can be supplied by an air driven generator,

- o (a) hydraulic motor generator, generator control unit.
- o (b) integrated drive generator, main battery.
- (c) hydraulic motor generator, main battery.

If choice c is selected set score to 1.

40. The generator control unit (GCU) protects against....

- o (a) bus under-current, over-voltage.
- o (b) under-current, over-frequency.
- (c) over-voltage, under-frequency.

If choice c is selected set score to 1.

41. When electrical load shedding occurs, electrical power is....

- (a) available to critical and essential equipment.
- o (b) always available to the galley.
- o (c) available to the utility busses.

If choice a is selected set score to 1.

42. A static inverter transforms....

- (a) 28 V_{DC} to 115 V_{AC}.
- o (b) 115 V_{AC} to 28 V_{DC}.
- o (c) 28 V_{AC} to 28 V_{DC}.

If choice a is selected set score to 1.

43. A circuit breaker:

- (a) should be allowed to cool before resetting.
- o (b) must be replaced after a circuit breaker trip.
- o (c) may never be reset.

If choice a is selected set score to 1.

44. External electrical power

- (a) supplies the aircraft with 115 VAC/400 Hz.
- o (b) can be applied in flight.
- o (c) can be connected in the hangar with engines running.

If choice a is selected set score to 1.

45. Comfortable seat cushions are often made of foam type materials. Is this authorized on an airplane?

- (a) Yes, but the cushions are covered with a fire blocking material, this will slow down the burning of the material.
- o (b) No, aircraft cushions are made out of pressed cotton and goose feathers. These pure natural products don't give toxic gases when burning.
- o (c) Yes, but the cushions are made of a special foam, which cannot burn.

If choice a is selected set score to 1.

46. What is the difference between an escape slide and an escape raft?

- o (a) Industry and manufacturers terminology. There is no difference.
- (b) An escape slide that is also designed to be used as a boat, is called an escape raft.
- o (c) An escape slide floating on the water, that remains pressurized for at least one hour is also called a raft.

If choice b is selected set score to 1.

47. What type of gas is used in the inflation cylinder of a life vest?

- (a) Carbon dioxide (CO₂)
- o (b) Argon (Ar)
- o (c) Nitrogen (N)

If choice a is selected set score to 1.

48. What subject does the FAR / EASA CS 25.853 covers on cabin upholstery materials?

- (a) This will regulate the fire resistance capabilities and toxic gas producing limits for all upholstery materials used on an aircraft.
- o (b) This will regulate the way cabin interiors must be built to be conform with the new 15G force rules.
- o (c) This will tell which designers of fabrics have a part 21 approval and may deliver to the aviation industry.

If choice a is selected set score to 1.

49. How can passengers seats (spacing or pitch) be adjusted on installation?

- (a) They are installed inside extrusion seat tracks with a 30-inch increment. This is the standard seat pitch requirement of ICAO. The seat itself can swivel 2 inch forward of aft on pivot points.
- (b) Seats are installed inside seat tracks with a 1-inch increment.
- (c) Seats are installed inside extrusion seat tracks with a 5-inch increment.

If choice b is selected set score to 1.

50. How many belts are attached to the buckle on an attendant's seat?

- (a) 2
- (b) 4,5 or 6
- (c) 3

If choice b is selected set score to 1.

51. How many cockpit seats do we find in a modern aircraft?

- (a) Mostly five. Captain, first officer, flight engineer, navigator, radio operator.
- (b) Mostly four. Captain, first officer, flight engineer and minimum one observer seat.
- (c) Mostly three. Captain, first officer and minimum one observer seat.

If choice c is selected set score to 1.

52. What is the best description for a "combi aircraft"?

- (a) This is an aircraft with a mixed configuration. This means that cargo also is loaded on the main deck passenger zone.
- (b) This just means that the aircraft transport passengers as well as cargo. Passengers in the upper lobe, cargo in the lower.
- (c) This is an aircraft with a mixed passenger configuration. This means that the aircraft has a mixed cabin lay out. (Ex. first/business/economy)

If choice a is selected set score to 1.

53. What are the two main operating principle used for fire detecting probes?

Operating on sensing a difference in pressure,....

- (a) or sensing a difference between resistance.

- o (b) or sensing a difference in light intensity. (infrared temperature measuring).
- o (c) or passing a current limit coming from a bimetal.

If choice a is selected set score to 1.

54. On most modern aircraft, how would you describe the engine fire extinguisher bottle(s).

- o (a) One spherical cylinders filled with dry powder.
- (b) Two or more spherical cylinders filled with halon gas.
- o (c) Per engine, two or more spherical cylinders filled with dry powder.

If choice b is selected set score to 1.

55. How is the APU extinguished in case of fire?

- o (a) By an aluminium spherical cylinder filled with powder, installed near the apu.
- (b) By steel spherical cylinder filled with halon, installed near the apu.
- o (c) By switching off the fuel pump.

If choice b is selected set score to 1.

56. How do you test the fire bottles of the toilet waste bins?

- o (a) When empty the bottle becomes black.
- (b) You need to weigh the bottle.
- o (c) You check the pressure indicator on the bottle.

If choice b is selected set score to 1.

57. What is the main reason to install only halon-type portable fire extinguisher in the cockpit?

- o (a) Halon avoids smoke, keeping the cockpit 'visual'.
- o (b) Because halon fire-bottles can be made much smaller and lighter and so much easier to handle by the pilot from the seat.
- (c) Because on fires in electronics you may only use halon.

If choice c is selected set score to 1.

58. What logic would you expect from an hydraulic operated flight control system in an aircraft with a fly by wire concept.

- o (a) Control column input - steel wire - computer - electrical wire - hydraulic actuator - control surface.
- o (b) Control column input - control valve - steel wire - hydraulic actuator - control surface.

- (c) Control column input - electrical wire - hydraulic actuator - control surface.

If choice c is selected set score to 1.

59. How would you describe the term "hydraulic servo system" in a powered flying control system?

- o (a) Is a system used where a power chamber gives pressure in a line, but the pressure never flows directly into a return line. (Brake systems)
- o (b) Is a system where a small hydraulic input will transmitted a feedback signal.
- (c) Is a system where a small input initiates a large power output, which is transmitted by a hydraulic piston-actuator to move for example a control surface.

If choice c is selected set score to 1.

60. What kind of flap configuration is used here?

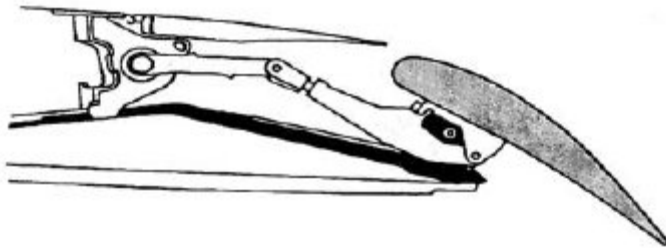

- (a) Track and carriage configuration.
- o (b) The fowler system.
- o (c) The hinged flap configuration.

If choice a is selected set score to 1.

61. By which control system is the active load control accomplished?

- (a) Electrical flight.
- o (b) Pure mechanical flight.
- o (c) By interruption by the pilot to activate the flight control system.

If choice a is selected set score to 1.

62. Why do we need to incorporate an artificial feel system in flight controls?

- o (a) Because technically you cannot join the two inputs, manual and auto pilot to one control if there is not an artificial feel system to connect to them.
- (b) Moving a control with a servo system requires so less force input that the control may overreact by lack of feedback counterforce. We will create artificially a force feedback in relation to degrees of input and even related to speed.

- o (c) The artificial feel in a servo mechanism is to allow to adjust the input force in relation of human force, this will keep the flying characteristics the same for every pilot. Smaller or female pilots have lesser muscle power.

If choice b is selected set score to 1.

63. What is the main purpose of having a correct cable tension and rigging?

- o (a) A correct cable tension will give the pilot a correct artificial feel during manoeuvres. A good rigging will give the control surface sufficient deflection in all required directions.
- o (b) A cable must be tensioned as low as possible but still just enough to not jump out of the pulley grooves. A good rigging will give the control surface sufficient deflection in all required directions.
- (c) A correct cable tension will give the pilot a good responsive control at all temperatures. A good rigging will give the control surface sufficient deflection in all required directions.

If choice c is selected set score to 1.

64. What is the purpose of a stick shaker?

- (a) It will warn the pilot by shaking the control column that is aircraft critically close to a stall.
- o (b) It will advise the pilot that he is in an active stall. The control column shakes, the pilot should immediately increase the thrust.
- o (c) It will warn the pilot that the auto slat system is activated.

If choice a is selected set score to 1.

65. What is the main purpose of the fuel system on board of an aircraft?

- o (a) Store a quantity of fuel on board in the wing tanks and be able to deliver this fuel to the on-wing engine.
- (b) Store the needed amount of fuel on board in the tanks and be able to deliver a constant amount of fuel under pressure to all engines.
- o (c) Store the needed amount of fuel on board in the wing tanks and be able to deliver a constant amount of fuel under gravity and action to all the engines.

If choice b is selected set score to 1.

66. In general, how many fuel tanks are installed in an aeroplane?

- o (a) Always two (each wing), or three (centre tank) for long haul flights.
- (b) Minimum as much as the number of main engines of the aircraft.
- o (c) Always four, two in each wing. Optional five, if the centre tank is used.

If choice b is selected set score to 1.

67. What is the purpose of a check valve at the outlet of the pressure pump?

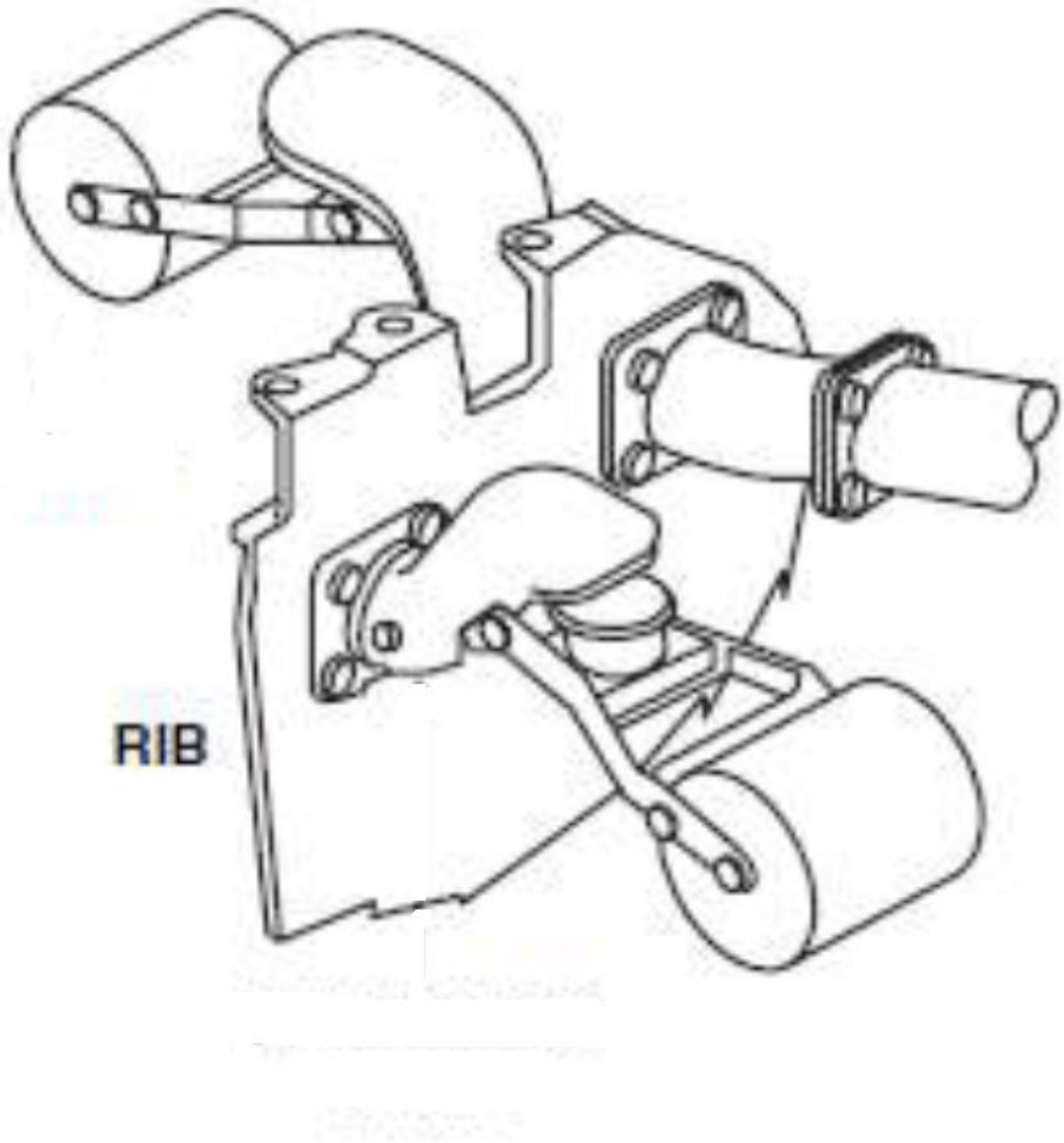

- (a) To allow removal of the pump.
- (b) To prevent suction cavitation.
- (c) To prevent return flow from another pump.

If choice c is selected set score to 1.

68. How would you call this valve?

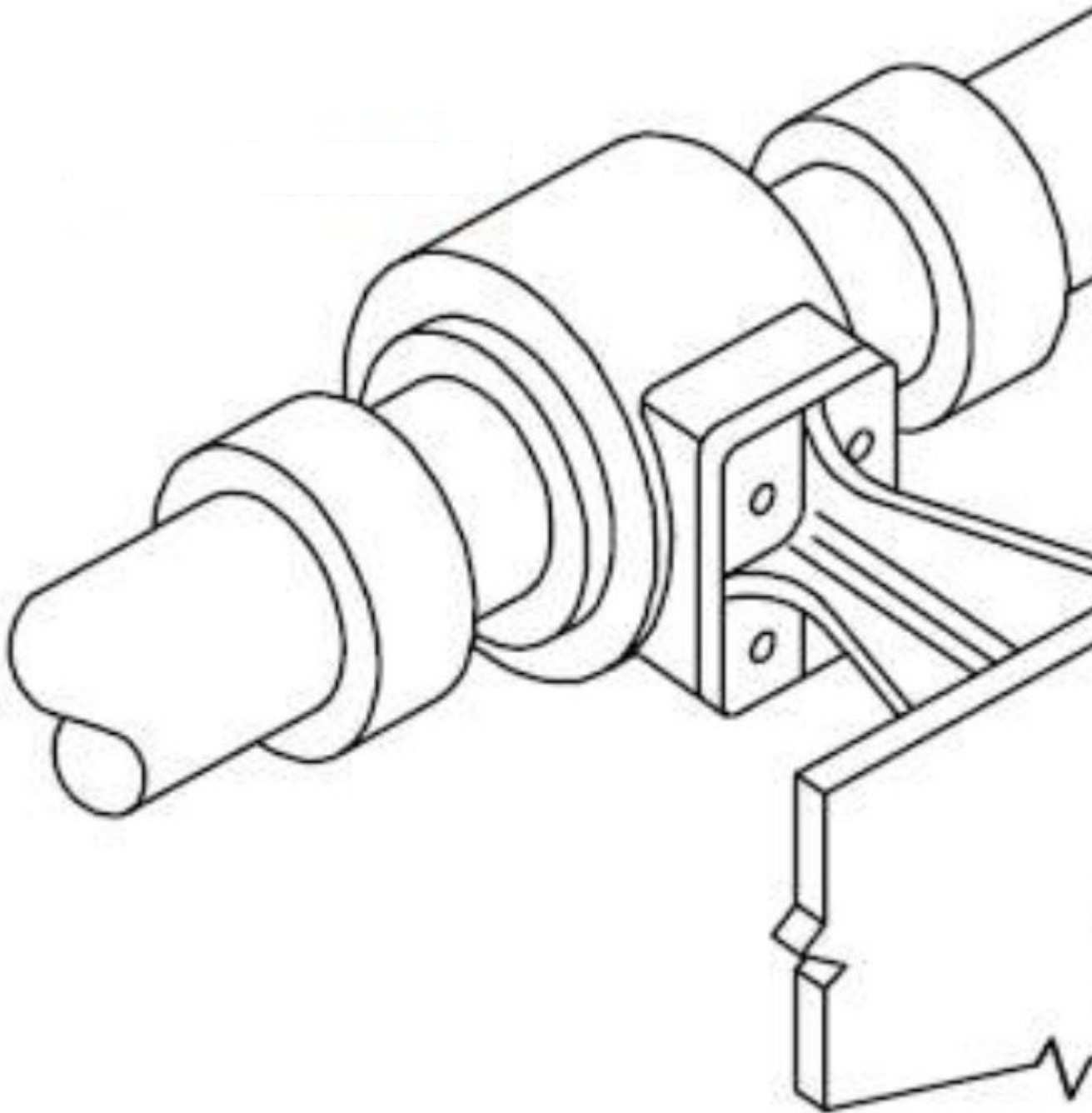

Tank Wall

- (a) Cross feed valve.
- o (b) Tank interconnecting valve.
- o (c) Centre tank valve.

If choice a is selected set score to 1.

69. What type of fuel quantity sensors are used inside the tank of modern aircraft?

- o (a) Infra-red probes.
- o (b) Floating level probes.
- (c) Capacitor type fuel probes.

If choice c is selected set score to 1.

70. What means 3000 psi?

- o (a) 3000 particles per system inspected.
- (b) 3000 pounds per square inch.
- o (c) 3000 pressure system indication.

If choice b is selected set score to 1.

71. What is the most common used hydraulic fluid used in modern aircraft?

- o (a) Lokoil avio
- (b) Skydrol
- o (c) Hydrofluid

If choice b is selected set score to 1.

72. What is the name of this unit?

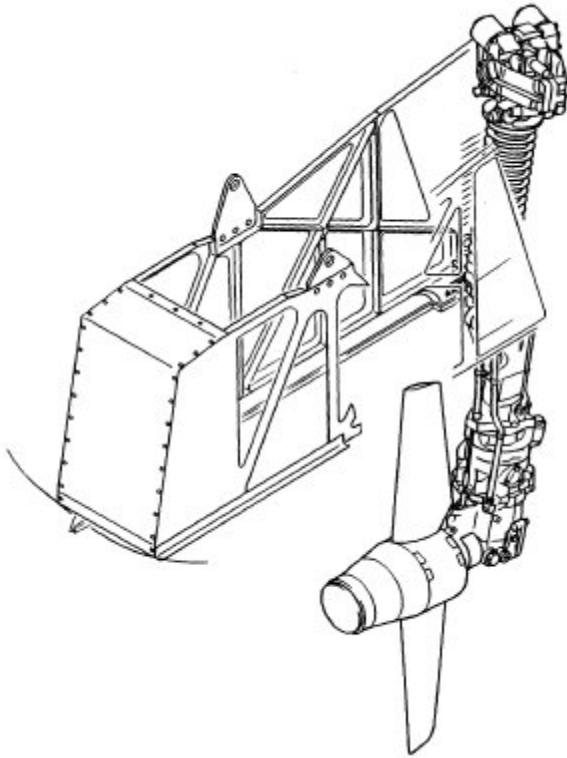

- (a) RAM, rotary air motor. Backup system for the pneumatic system.
- (b) RAT, ram air turbine. When extended in emergency, the turbine can drive a generator and/or hydraulic pump.
- (c) RAT, rotary blade ejection jack. Will eject automatically as backup when the APU fails.

If choice b is selected set score to 1.

73. Why do we need filters in a hydraulic system?

- (a) A filter will keep dirt out of the system but the size of the opening in the wire gauze regulates mainly the flow inside the system.
- (b) A filter is needed to protect the system from dirt and metal particles.
- (c) A filter is used mainly for inspections. It will tell us the degradation of the oil quality and when to change it.

If choice b is selected set score to 1.

74. What is a pressure relief valve?

It is a unit that protects....

- o (a) failure of other components due to over pressure. It will release the overpressure in that line section and redirect the pressure to the inlet of that unit or valve.
- o (b) the complete system for overpressure. It will release the overpressure and drain it.
- (c) failure of other components due to over pressure. It will release the overpressure in that line section and dump it into the return line.

If choice c is selected set score to 1.

75. What are the conditions for ice to be formed on a surface?

Ice will be formed....

- (a) on a surface when humid air encounters a surface and both air and surface are below freezing temperature.
- o (b) when the air humidity in % \times surface temperature is below $1,472^{\circ}\text{C}$ (Example: $65\% \text{ humidity} \times 2^{\circ}\text{C surface temp} = 1,3^{\circ}\text{C}$ is risk of icing).
- o (c) from the moment that the algebraic sum of the air and the surface temperature is below freezing temperature.

If choice a is selected set score to 1.

76. Why do the pitot probes need to be heated?

- o (a) All protrusions on the fuselage will accumulate ice. A ice blocked pitot tube will register a too high airspeed which can lead to fatal accidents.
- o (b) Protruding items in the forward section can accumulate ice. A with ice blocked pitot tube will register an incorrect angle of attack.
- (c) Protruding items in the nose area of the fuselage will accumulate ice. A with ice block pitot tube will register a too low airspeed.

If choice c is selected set score to 1.

77. What is a de-icing mat?

- (a) Electrical heating elements embedded into the leading edge of engine intake.
- o (b) A rubber boot on a leading edge through which intermittently pneumatic air is blown. Breaking of ice by using the flexibility of rubber.
- o (c) Electrical elements around a duct inside the wing leading edge to warm up the duct air.

If choice a is selected set score to 1.

78. What precaution should be taken by using the chemical rain repellent?

- (a) It is only allowed to spray it on a dry windshield.
- (b) It is only allowed to spray it on a wet windshield.
- (c) It is to use only on the ground for better visibility.

If choice b is selected set score to 1.

79. Why does each pilot has his own wiper control switch?

- (a) For system redundancy in case of failure.
- (b) Since the windows each have another relative angle versus the airstream (and so rain) one side will always receive considerable more water then the other.
- (c) So they can select each a different wiper speed for their own visibility comfort.

If choice a is selected set score to 1.

80. What is the function of the tapered metering pin inside the shock absorber?

- (a) It must regulate a constant flow of oil from the lower chamber to the upper chamber during compression.
- (b) The pin will gear retraction, the pin will be pulled away so the nitrogen and oil can change from chamber. Nitrogen on highest point.
- (c) During gear compression the pin will gradually narrow the section, so the oil flowing from one chamber to another will become more difficult, making the damping harder.

If choice c is selected set score to 1.

81. What happens when we set the landing gear lever in the "OFF" position?

- (a) All the landing gear retraction/extension components are set to return line.
- (b) This is a safety position for maintenance purposes.
- (c) It will inhibit the emergency extension.

If choice a is selected set score to 1.

82. What does the indication of a red landing gear warning light mean?

- (a) The gear is still in transit and is not locked.
- (b) The gear is locked in upper position.
- (c) The gear is locked in down position.

If choice a is selected set score to 1.

83. What is the function of the anti-skid system?

It will prevent skidding of the wheels by....

- (a) monitoring the rate of wheel speed deceleration.
- o (b) monitoring the rate of aircraft speed deceleration.
- o (c) releasing the brake pressure. When the wheel speed is less than 50% of the aircraft speed.

If choice a is selected set score to 1.

84. How would you describe the used profile of an underinflated tire?

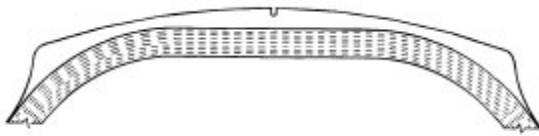

- o (a) The outboard ribs on the tire are still present while the middle rib is used.
- o (b) The centre rib and the ribs towards the centre of the aircraft are worn while the outboard profile of the tire still is reasonably good.
- (c) The middle rib is still present while the rest of the profile is used.

If choice c is selected set score to 1.

85. How does the pilot usually steer the aircraft (at low speed) on ground? (commercial jets)

- (a) By mean of a steering wheel or tiller.
- o (b) By alternate braking.
- o (c) By moving the rudder pedals.

If choice a is selected set score to 1.

86. Which external lights are always illuminated while the aircraft is in operation?

- o (a) Belly lights.
- (b) Navigation lights.
- o (c) Landing lights.

If choice b is selected set score to 1.

87. During a flight in the night, the cockpit instruments are illuminated by:

- (a) Instrument lighting, flood lights and spot lights.

- o (b) Only the primary flight instruments are illuminated, dark cockpit philosophy.
- o (c) Direct lighting

If choice a is selected set score to 1.

88. Why are luminescent floor strips installed in a passenger aircraft?

- o (a) Flood lighting is used in the cabin for the visual comfort of passengers.
- o (b) To indicate that luggage is not allowed to be placed in the aisle.
- (c) To guide passengers to exits in case of emergencies.

If choice c is selected set score to 1.

89. Most modern aircraft have in the cockpit a diluter demand oxygen system. Explain this function.

- o (a) Is a system that delivers 100% O₂ to the mask each time the pilot inhales.
- (b) Is a system that delivers an air mixture through the mask each time the pilot inhales.
- o (c) Is a system that delivers an nitrogen mixture through the mask each time the pilot inhales.

If choice b is selected set score to 1.

90. What will happen if, for any reason, the oxygen bottle pressure arise critically high?

- (a) A frangible disc will break at a set pressure. This will discharge the bottle to ambient.
- o (b) An over press-valve is installed on the head of the cylinder. The valve will open and discharge the overpressure overboard. The over press-valve closes again when the pressure is within limits.
- o (c) A warning light will be set in the cockpit. The pilots should set their O₂ masks in auto emergency flow mode until the pressure drops below critical value and the alarm the stops.

If choice a is selected set score to 1.

91. How and where is the oxygen pressure regulated?

- o (a) The bottle pressure is delivered to the mask. Inside the mask there is a regulator that reduces the pressure to 40 psi each time the pilot inhales.
- o (b) A medium pressure regulator to 500psi is installed on the oxygen bottle. A low pressure reducer to 40psi is installed in the mask.
- (c) A low pressure reducer regulates 1800psi bottle pressure to 50-75 psi pressure for delivering to the mask. The reducer is installed on or near the oxygen bottle.

If choice c is selected set score to 1.

92. What is a big advantage in using pneumatic power?

- (a) The transfer of energy has a better to power/weight ratio than electrical or hydraulic power systems.
- o (b) It is the cheapest technique to use. Generating hydraulic or electrical power cost extra fuel money while the engine is nearly a unlimited source pressurized hot air.
- o (c) It is the cheapest technique of power transfer to build.

If choice a is selected set score to 1.

93. Which sources can provide pneumatic power to the aircraft in flight?

- (a) Engines - APU
- o (b) Engines - Nitrogen reserve bottles
- o (c) Engines - RAT (ram air turbine)

If choice a is selected set score to 1.

94. How is the bleed air from an APU regulated?

- o (a) The APU will change its speed to keep the outlet pressure to a constant 45 psi.
- o (b) The APU bleed air-port is fitted with a pressure regulating valve. The pressure is regulated to 45psi.
- (c) The APU bleed air is tapped from the load compressor.

If choice c is selected set score to 1.

95. How is the potable water tank is pressurized?

- (a) Each tank is pressurized by the pneumatic system of the aircraft. Some aircraft models have a backup electrical compressor.
- o (b) Each water tank has a small electrical compressor.
- o (c) On ground the potable water tanks are pressurized by an electrical compressor. In flight the differential atmospheric pressure will provide the tank pressurization.

If choice a is selected set score to 1.

96. How would you describe a vacuum toilet system?

- o (a) A system where the waste is moved to a central waste tank via a vacuum pressurized water system.
- o (b) A vacuum pump will move the waste from the bowl into the tank just below.
- (c) A system where the waste is moved to a central tank by means of suction.

If choice c is selected set score to 1.

97. An on-board maintenance system is used....

- (a) to repair an engine anomaly in flight
- (b) to confirm faults in several aircraft systems
- (c) to repair the airframe on the ground

If choice b is selected set score to 1.

98. The validity of the current data loaded into an aircraft can be checked....

- (a) on the data loader.
- (b) by using the FMS MCDU.
- (c) only before loading.

If choice b is selected set score to 1.

99. Engine health monitoring on modern aircraft is achieved by:

- (a) the flight management computer
- (b) the cockpit EICAS display
- (c) the low cycle fatigue counter (LCFC) or engine monitoring recorder

If choice c is selected set score to 1.

100. Engine data is routed for display to the flight deck by:

- (a) a crew wifi lan module.
- (b) AFDX cables and routers.
- (c) a RJ45 8 pins connector.

If choice b is selected set score to 1.

101. The arinc 653 specifications are developed for:

- (a) The IMA data communication
- (b) only for maintenance purposes
- (c) The IMA operating system

If choice c is selected set score to 1.

102. Avionics full duplex (AFDX) cable can be recognized by:

- (a) 8 connector pins
- (b) 4 connector pins
- (c) 16 connector pins

If choice b is selected set score to 1.

103. In most transport aircraft, the cabin systems can be managed from:

- (a) the cockpit
- (b) the passengers seats
- (c) the cabin attendant panel

If choice c is selected set score to 1.

104. In modern aircraft, the passenger manifest (list with all passenger names) can be found?

- (a) only on the ground at the airport of departure
- (b) loaded in the cabin network server
- (c) on a paper list in the cockpit

If choice b is selected set score to 1.

105. The cabin monitoring system consist of:

- (a) inflight entertainment system and cabin video monitoring system
- (b) cockpit door surveillance system and cabin video monitoring system
- (c) main multiplexer and seat electronics box

If choice b is selected set score to 1.

106. Inside modern transport aircraft, two main data networks are defined.

These networks are....

- (a) crew wireless lan and open data network
- (b) avionics or isolated data network and open data network
- (c) isolated data network and crew wireless lan

If choice b is selected set score to 1.

107. Non-critical aircraft data is accessible via the:

- (a) common data network
- (b) open data network
- (c) isolated data network

If choice b is selected set score to 1.

108. The electronic flight bag system can help the flight crew do calculations for:

- (a) in-flight navigation
- (b) aircraft weight and balance
- (c) engine control functions

If choice b is selected set score to 1.

***If assessment score is 75% to 100% Pass
If assessment score is 0% to 74% Fail***